

# Installation Instructions

## Notes and Warnings:

This manual contains important information about the installation, and operation of the simpleSwitch™.

- READ THIS MANUAL CAREFULLY before installing or servicing this product.
- Improper installation or operation can result in severe injury or property damage.
- Installation and repair must only be carried out by a licensed and qualified service person who has: thoroughly read, understands, and strictly adheres to, these instructions, as well as the instructions for electrical devices that are to be connected to the simpleSwitch240CT™.
- The manufacturer and seller are not responsible for any damage that may happen from improper installation or improper use.
- The simpleSwitch240CT™ is to be installed and/or used in accordance with national and local electrical codes.
- **Electric Vehicle (EV) home chargers have settings that must be configured on the EV charger device (not the car) prior to charging with simpleSwitch240CT™. Simply stated, EV chargers must be set to a maximum of 32 Amps charging. See Step 21.**
- Appliance/device power draw above 40 Amps will damage the simpleSwitch240CT™

<b>Specifications:</b>	
Model	<b>simpleSwitch 240CT™</b>
Weight (pounds)	5 lbs.
Dimensions (W x H x D in)	7.58 x 7.58 x 4.90 in
Power Connection (Volts/Amps)	208-240VAC Single Ph      208-240V – A.C. Single Ph
Full Load Rating - Continuous Use	40 Amps      40 Amps
Suggested Secondary Appliance Amperage	<36 Amps      <36 Amps
Maximum Breaker Size	50 Amps
Contactors Type	Latching
Enclosure Rating NEMA	Type 1, 2, 3R, 4, 4X, 6, 6P, 12, 13
Mounting	Indoors / Outdoors
Delay Time	A delay of fifteen (15) minutes to restore power to the switched appliance after Current Transformers (CTs) have measured power usage under set threshold values
Standard(s) for Safety:	UL 916, Energy Management Equipment CSA C22.2 No. 205-17 Signal Equipment
Testing	UL Certificate of Compliance E510161 US/CAN LISTED



## Installation Steps

### 1. Determine your application and approximate location of simpleSwitch 240CT™.

Examples for placement:

#### a. Main Panel/Service Line Application:

- “How does it Work” summary: **simpleSwitch 240CT™** will measure power load on the **WHOLE** panel and switch off the **simpleSwitch 240CT™** connected appliance/device if whole panel load exceeds 80% threshold (i.e. shed power load to connected appliance).
- In this application the **simpleSwitch 240CT™** external Current Transformers (CTs) are connected to the main service line input wires, inside the electrical panel (to monitor if power draw on whole panel exceeds thresholds).
- The **simpleSwitch 240CT™** is typically mounted close to the electrical panel.
- The power source into the **simpleSwitch 240CT™** is from a circuit breaker that is connected down-stream (same panel or nearby subpanel) of where the CT's are measuring load.

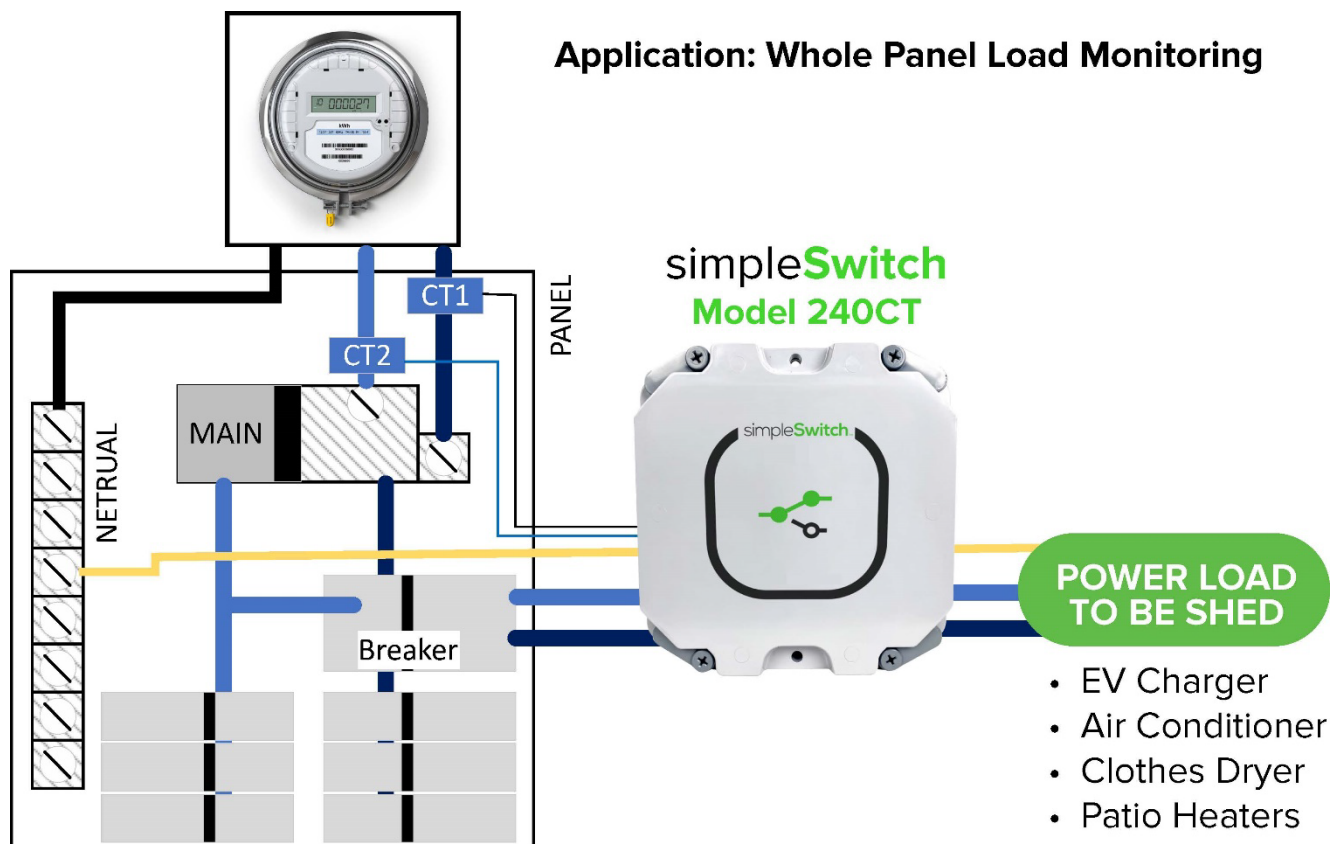

b. **Subpanel or Branch Feeder Application:**

- “How does it Work” summary: **simpleSwitch 240CT™** will measure power load on the Subpanel and switch off the **simpleSwitch 240CT™** connected appliance/device if Subpanel load exceeds 80% threshold (i.e. shed power load to connected appliance).
- In this application the **simpleSwitch 240CT™** external Current Transformers (CTs) are connected to the branch feeder input wires to the Subpanel, inside the Subpanel, (to monitor if power draw on Subpanel exceeds thresholds).
- The **simpleSwitch 240CT™** is typically mounted close to the electrical panel.
- The power source into the **simpleSwitch 240CT™** is from a circuit breaker that is connected down-stream (same Subpanel) of where the CT’s are measuring load.

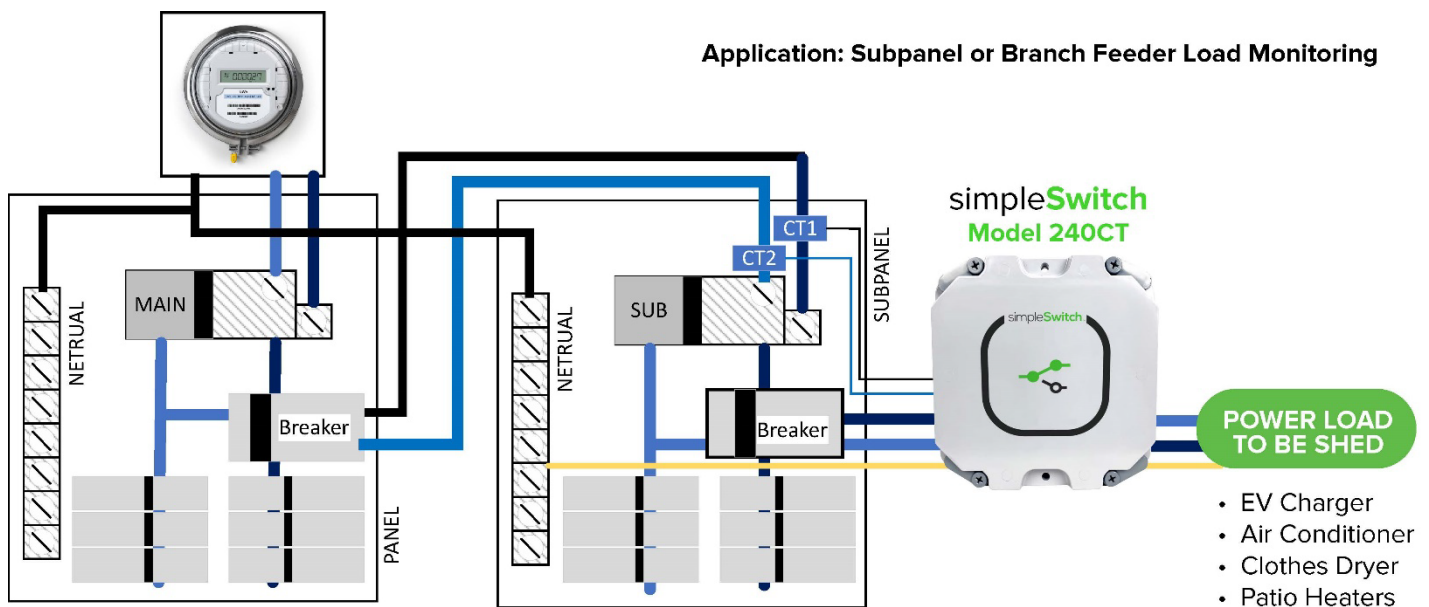

c. **Parking Garage Application (e.g. Electric Vehicle Charger or Auxiliary Plug):**

- **“How does it Work” summary:** **simpleSwitch 240CT™** will measure the power load being drawn from an individual electrical panel (typically located inside an apartment/condo suite) and switch off the **simpleSwitch 240CT™** connected appliance/device (e.g. Electric Vehicle Charger or Auxiliary Plug) if power draw exceeds 80% threshold (i.e. shed power load to connected appliance).
- **Mounting Location simpleSwitch 240CT™:** The **simpleSwitch 240CT™** is typically mounted in the parking garage, near the meter bank.
- **Power Entry into simpleSwitch 240CT™:** A Tap Breaker will be required to be installed prior to the power entry into the **simpleSwitch 240CT™**
- **Power Exit from simpleSwitch 240CT™:** Wire will exit **simpleSwitch 240CT™** and be ran to the location of the Auxiliary Load to be shed (e.g. Electric Vehicle Charger or receptacle).
- **CT Mount:**
  - In this application the **simpleSwitch 240CT™** external Current Transformers (CTs) are connected to the electric Feeder Line, between the meter and an individual electrical panel.
  - The CTs are typically fitted around the feeder wires inside an appropriate wire raceway trough, or wire duct/gutter, or junction box (to monitor if power draw from panel in apartment/condo suite exceeds thresholds).

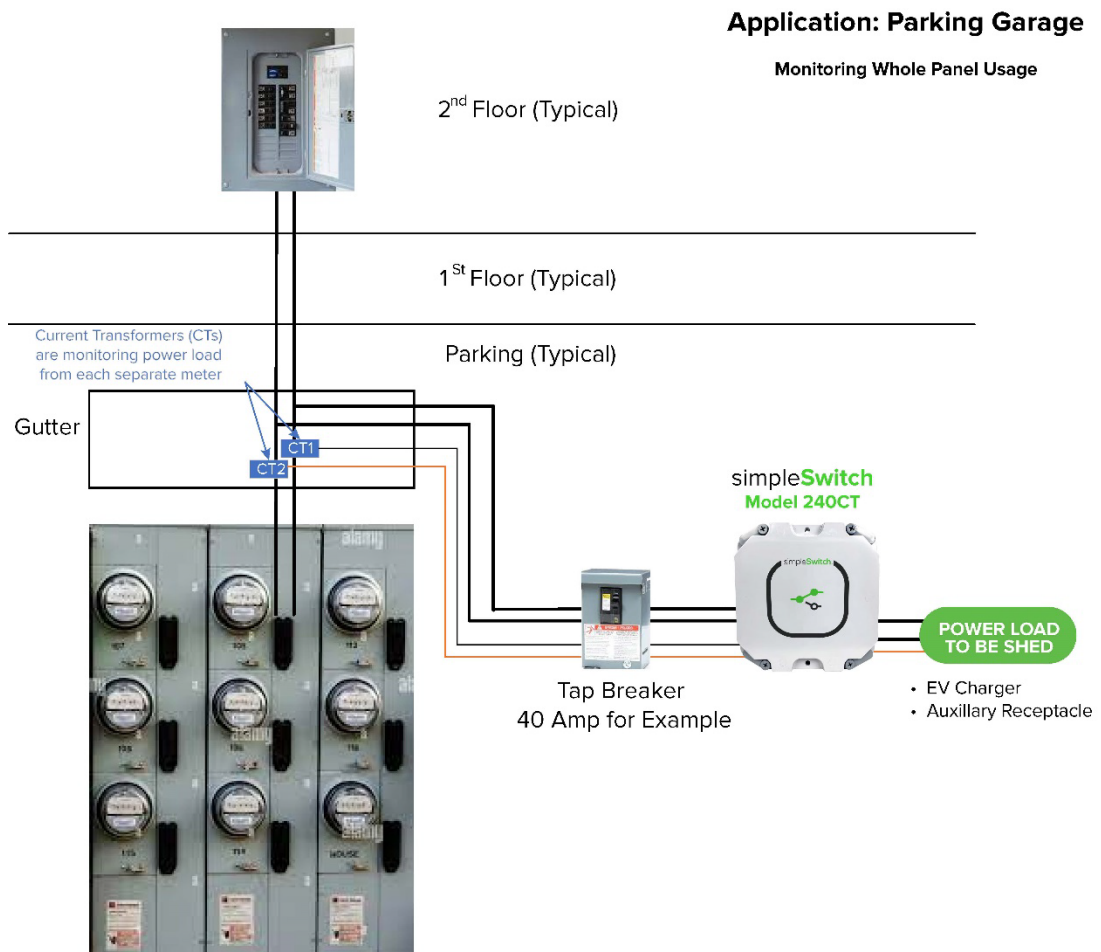

**2. Determine the source of power the simpleSwitch 240CT™ will monitor and be connected to.**

Typical Configuration Options:

- a. Main panel load monitoring via Current Transformers (CTs), with main panel circuit breaker connection (e.g. see illustration example in 1(a)).
- b. Main panel load monitoring via CTs, with subpanel circuit breaker connection
- c. Subpanel load monitoring via CTs, with subpanel circuit breaker connection (e.g. see illustration example in 1(b)).
- d. Main panel load monitoring via CTs, with branch feeder line connection (e.g. parking garage application, see illustration example in 1(c))

**3. Determine the circuit breaker or tap breaker that will precede the simpleSwitch 240CT™.**

Typical Configuration Options:

a. Circuit Breaker Connection:

- For applications where the **simpleSwitch 240CT™** will be monitoring power load in a panel or subpanel (through CTs) prior to circuit breakers, the circuit breakers in that panel or subpanel will serve as the breaker that precedes the **simpleSwitch 240CT™**.
- Examples of Circuit Breaker Connection are in 2(a), 2(b), and 2(c) above.

b. Tap Breaker Connection:

- For applications where the **simpleSwitch 240CT™** will be monitoring power load on a Feeder Line between the Meter and electrical panel (through CTs), and **cannot** be practically connected to a circuit breaker in a panel or subpanel (e.g. due to panel being located on different floor of apartment/condo tower), a Tap Breaker will need to be installed between the Meter and electric panel.
- Tap Breaker installation to follow all local tap breaker rules and code requirements and must be done by a professional electrician.  
*Note for context only (not instructional): Tap Breaker installation will typically require power to the meter be shut off by local utility company, the Feeder Line between the Meter and panel spliced, connections made in an appropriate wire raceway trough (or wire duct/gutter, or junction box) creating a power feed off the Feeder Line, to a Tap Breaker that proceeds the **simpleSwitch 240CT™**.*
- Preceding the **simpleSwitch 240CT™** a Tap Breaker will need to be installed of appropriate size for the device/appliance being connected to the **simpleSwitch 240CT™**.
- Examples of Tap Breaker Connection is 2(d) above (e.g. parking garage).

**4. Determine cable size and type from the power source to the simpleSwitch 240CT™.**

- The simpleSwitch 240CT™ will accommodate:
  - Minimum size conductor #14 American Wire Gauge (AWG)
  - Maximum size conductor #6 American Wire Gauge (AWG)
- Considerations:
  - When determining cable size and type, factor in all local code requirements.

5. **Determine cable pathways** from the power source to the **simpleSwitch 240CT™**.

- Cable pathways to be designed for cable entry from the side (lower ½) or bottom (not top).
- Considerations:
  - Determine input and output cable pathways before mounting the **simpleSwitch 240CT™**.
  - Consider any junction boxes (or similar wire raceway troughs, or wire ducts, wire gutters), or other equipment or hardware to accompany the installation.
  - Consider radius of cable bends when planning cable pathway and device placement.

6. **Mount Conduit Fittings** to the **simpleSwitch 240CT™**.

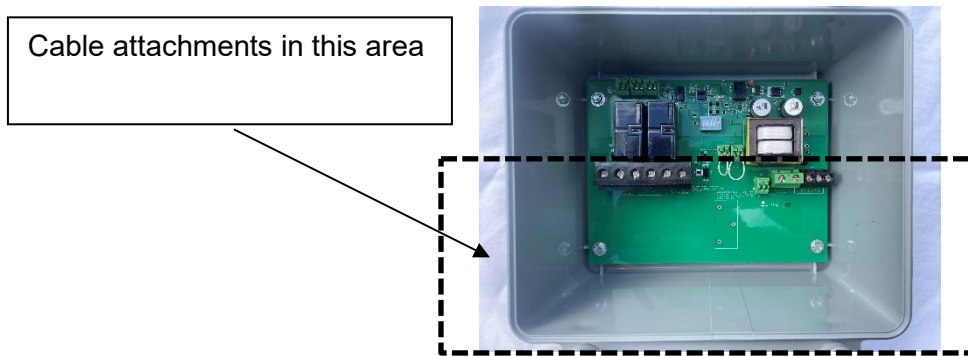

**CAUTION: Plan holes and drill with mild pressure to avoid touching and damaging the circuit board inside of the simpleSwitch 240CT™.**

- a. Use a fine-tooth hole saw to make, one hole for the input cable connector, one hole for the output connector, and one hole for the CT connector **in the side or bottom of the simpleSwitch 240CT™**.
- b. Avoid entry from top of simpleSwitch to reduce risk of water intrusion and inadvertent grounding of circuit board.
- c. Typical hole sizes:
  - 1/2" conduit connectors require a 7/8" hole.
  - 3/4" conduit connectors require a 1-1/8" hole.
  - 1" conduit connectors require 1-3/8" hole.
- d. Mount conduit/cable connectors to the **simpleSwitch 240CT™** housing.

**7. Mount simpleSwitch 240CT™ to structure with appropriate screws or anchors.**

- Use ONLY the external mounting holes. DO NOT put fasteners through the inside of the box because it may damage internal electronics.
- Four (4) external holes total, located in 4 corners of housing.

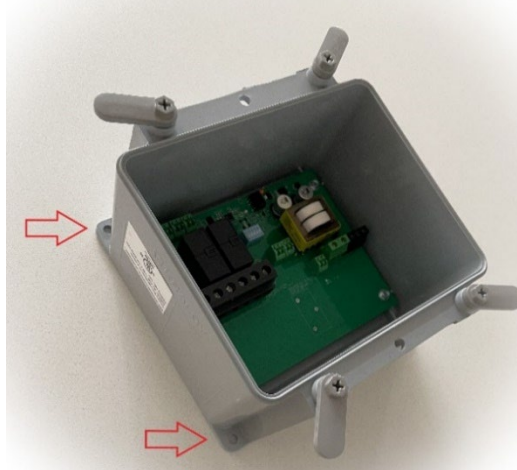

**8. Turn off the power source that is designated for simpleSwitch 240CT™.**

**9. Run cable from power source to the simpleSwitch 240CT™.**

- a. From the designated power source (e.g. circuit breaker from electric panel, or Tap Breaker supplied from Feeder Line) run cable into to the **simpleSwitch 240CT™** through the input connector leaving 8 inches of extra cable for stripping and connecting.
- b. Use conduit if required by local code.
- c. Note:
  - Minimum size conductor #14 AWG
  - Maximum size conductor #6

**10. Run cables from simpleSwitch 240CT™ to appliance/device.**

- a. From one exit fitting in the **simpleSwitch 240CT™**, run a cable through an exit connector, to the appliance/device or the power outlet required for the appliance/device (e.g. Auxiliary power receptacle, EV Charger receptacle)
- b. Leave 8 inches of extra cable in the **simpleSwitch 240CT™** for stripping and connections.
- c. Use conduit if required by local code.

**11. Connections should be made similar to the image below (see steps 12, 13, 14, 15, below).**

- a. Note: DIP switch selection and positioning instructions #18
- b. Note: LED status indicator description #21 to #24

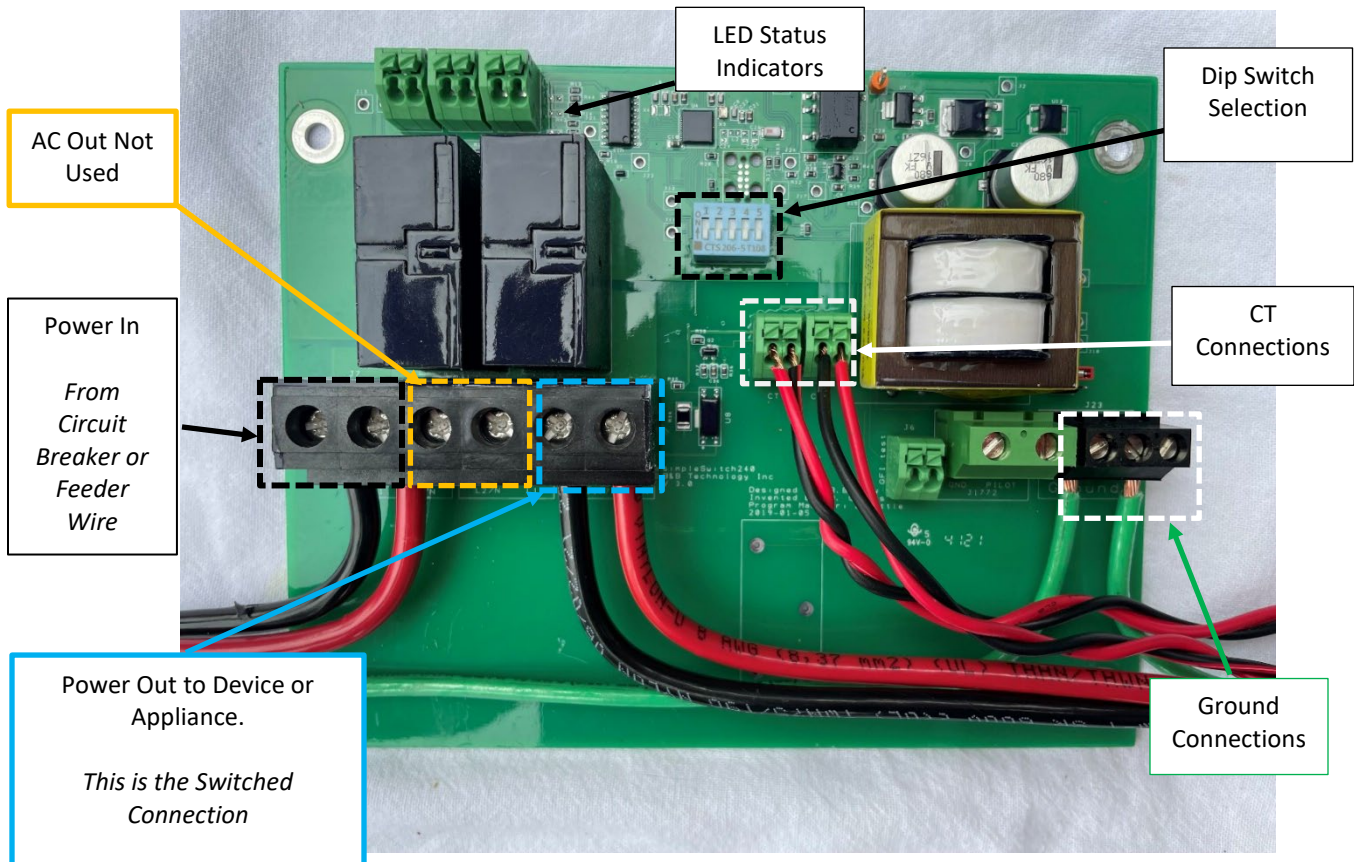

**12. Connect the power feed (Power In) to the Terminal Strip inside the simpleSwitch 240CT™ housing.**

- a. Strip 3/8" of the shielding from the red and black conductors.
- b. If present, the neutral wire is not connected to Terminal Strip (see instruction #16).
- c. The red and black wires are connected to the terminal strip in the **simpleSwitch 240CT™** and labeled on the circuit board as **AC IN**:
  - **Red connects to AC IN, L2/N.**
  - **Black connects to AC IN, L1.**

**13. Connect the appliance/device to the Terminal Strip.**

- a. Strip 3/8" of the shielding from the red and black conductors.
- b. If present, the neutral wire is not connected to Terminal Strip (see instruction #16).
- c. The red and black wires are connected to the terminal strip in the **simpleSwitch 240CT™** and labeled on the circuit board as **AC OUT SW**:
  - **Red connects to AC OUT SW, L2/N.**
  - **Black connects to AC OUT SW, L1.**



#### 14. Connect ground wire.

- a. Connect the two ground wires into connection ports labeled GROUND.

#### 15. Connect CT wires.

- a. The **simpleSwitch 240CT™** comes supplied with two Current Transformers (CTs).
- b. Connect the two wires from a CT into connection port labeled CT1.
- c. Connect the two wires from the other CT into connection port labeled CT2.
- d. Note: The CT connection ports on the **simpleSwitch 240CT™** do not have polarity.

#### 16. Devices with 120V Neutral Wire.

- a. For devices that contain a neutral wire and use 120V power (e.g. clock on an electric range), the neutral wire should be connected within the **simpleSwitch 240CT™** to maintain power to the 120V application (e.g. clock on an electric range).
- b. To connect neutral wires together:
  - Neutral wires may be spliced and the **simpleSwitch 240CT™** may be used as a junction box to house the spliced wires. Position the spliced wires in the bottom ½ of the **simpleSwitch 240CT™** housing.
  - The installer may use a multitap connector or push wire terminal block (See examples below).
  - If the inspector requires that the neutral block be mounted, there are mounted terminal blocks available that will mount to the inside bottom of the **simpleSwitch 240CT™**.



Push Wire Connector  
(Example. Not Supplied)



Push Wire Connector  
(Example. Not Supplied)



Mounted Push Wire Connector  
(Example. Not Supplied)



Multitap Connector  
(Example. Not Supplied)

## 17. Install the two Current Transformers (CTs).

- a. Install the two CTs (supplied) on the power source being monitored (service line into panel, line into subpanel, branch feeder line between meter and panel). Each CT is clamped around 1 black service wire.
- b. *Note to installer: No CT is required on the neutral or ground wire.*
- c. Note local codes and panel design will vary – follow your local code. The CT wires connecting the monitoring clamp to the **simpleSwitch 240CT™** are typically required to be ran out of panel through their own independent conduit, and without penetration in the upper portion of panel (do not run through covered portion of upper panel).

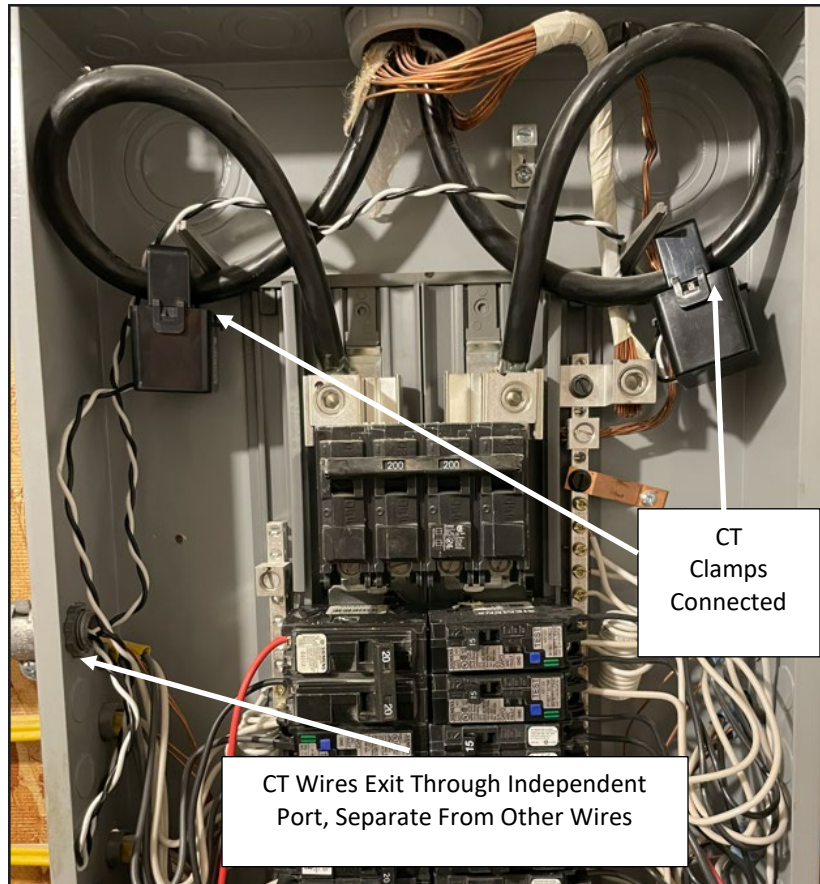

**18. Set DIP Switch Position.**

- a. Based on the amperage value of breaker or feeder being monitored, configure the DIP switches to the corresponding positions.
- b. See table below:

Breaker Current	CT Scale	Maximum Charge Current	Trip off Current	trip On Current	sw1	sw2	sw3	sw4	sw5	DIP Switch Position
200	200	32	162	127	Down	Down	Up	Down	Down	
175	200	32	142	107	Up	Down	Up	Down	Down	
150	200	32	122	87	Down	Up	Up	Down	Down	
125	200	32	102	67	Up	Up	Up	Down	Down	
100	200	32	82	47	Down	Down	Down	Up	Down	
90	200	32	74	39	Up	Down	Down	Up	Down	
80	200	32	66	31	Down	Up	Down	Up	Down	
70	200	32	58	23	Up	Up	Down	Up	Down	
60	200	32	50	15	Down	Down	Up	Up	Down	
50	200	32	42	7	Up	Down	Up	Up	Down	

**19. Install conductor taps if using service or branch feeder for power source.**

**20. Finish installation of any modified or new junction boxes, wire raceway troughs wire ducts/gutters, and power receptacle outlets.**

**21. Turn off calls for power from connected device/appliance and turn power on.**

- a. Ensure calls for power are turned off from electrical devices connected to the simpleSwitch (e.g., turn off call for A/C, turn off manual burners on range, turn off manual heater dials).
- b. Turn on designated breaker. The power on indicator LED will light Green.
- c. Approximately 2 seconds later the Secondary will switch on.

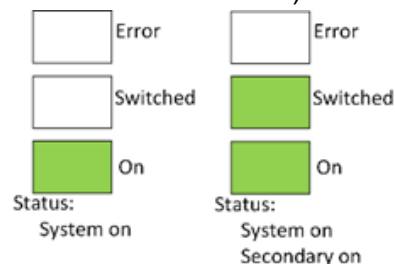

## 22. Electric Vehicle (EV) Charger.

- a. Set car charger device PRIOR to plugging charger into the car (as damage to **simpleSwitch™** may result if car charger device is not properly set).
- b. Follow instructions from the EV charger supplier to ensure the **CHARGER DEVICE (NOT THE CAR) is set to a maximum charge rate of 32 Amps**. Higher amperage chargers may be connected to **simpleSwitch 240** but **must: be set to a maximum of 32 Amp charge rate on the Wall Charger itself (not the vehicle)**, and other electrical connections sized according to standards and codes.
- c. If an Overcurrent Condition exists, the Secondary will switch off and the error status LED will light RED. The system will retry in 5 minutes.
- d. Express Disclaimer: in no case shall the manufacturer of the **simpleSwitch 240CT™** or its distributors or resellers, be responsible for improper installation or failure or damage to an electrical device connected to the **simpleSwitch 240CT™** or the **simpleSwitch 240CT™** device itself or other property, due these instructions not being strictly followed. An installer, service provider, and homeowner should only follow these written instructions.
- e. In the event clarification is required, contact **simpleSwitch** technical support prior to completing installation, and prior to activating car charging.

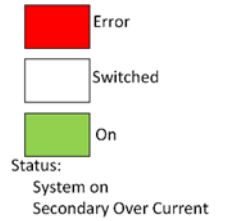

## 23. Check all internal **simpleSwitch 240CT™** connections for power with a multi meter.

- a. 208-240 volts at the AC IN connection.
- b. 208-240 volts at the AC OUT SW connection.
- c. AC Out will read 208-240 volts. NO connections are made to these terminals with the **simpleSwitch 240CT™** application.

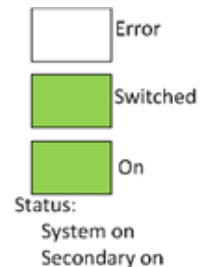

## 24. Note on Delay.

- When testing or operating and the power usage is over 80% of the allowed power threshold the switch will turn off power to the switched device/appliance port.
- There will be a fifteen **(15) minute proofing DELAY** before AC OUT SW power is restored.

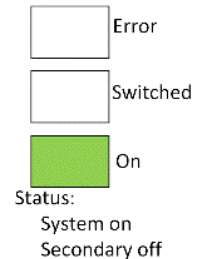

## 25. Install all covers.